DEPARTMENT OF THE ARMY TECHNICAL BULLETIN

CALIBRATION PROCEDURE FOR
OSCILLOSCOPE,
TEKTRONIX TYPES 317 (AN/USM-154)
AND RM17

Headquarters, Department of the Army, Washington, DC
22 September 1975

TB 9-6625-1172-35, 30 August 1974, is changed as follows:

The title is changed as shown above.

1. Remove old pages and insert new pages as indicated below. New or changed material is indicated by a vertical bar in the margin of the page.

Remove pages
1 through 6

Insert Pages
1 through 6

2. File this change sheet in front of the publication for reference purposes.
By Order of the Secretary of the Army:

Official:

FRED C. WEYAND
General, United States Army
Chief of Staff

PAUL T. SMITH
Major General, United States Army
The Adjutant General

Distribution:

To be distributed in accordance with DA Form 12-34A (qty rqr block No. 75), requirements for Calibration Procedures Publications.

This publication is a courtesy quick copy from the UNITED STATES ARMY ADJUTANT GENERAL PUBLICATIONS CENTER, ST. LOUIS, MISSOURI, to meet your needs while we are replenishing our regular stock.

10. Crt Geometry and Astigmatism graticule line.

a. Performance Check

(1) Connect time-mark generator (A6) to TI VERTICAL INPUT, using cable (B5) and if necessary, adapter (B2). Adjust time-mark generator for .1 mS marker output.

(2) Adjust TI POSITIONING controls to aline top of markers with top horizontal graticule line and extending across full horizontal range of crt. If markers displayed on crt are not parallel with vertical graticule lines, perform b(l) below.

(3) Reposition TI waveform to display both the baseline and markers. If sharp focus of crt display cannot be obtained by adjusting front panel FOCUS control, perform b(2) below.

b. Adjustments

(1) Adjust R861 (fig. 1) (GEOM ADJ R861, fig. 2) until markers are parallel with vertical

(2) Adjust R860 (fig. 1) (ASTIG R856, fig. 2) in conjunction with FOCUS control for sharpest focus of displayed baseline and markers.

11. Calibrator Accuracy

a. Performance Check

(1) Turn TI POWER switch to off (down position) and remove V875 (fig. 3), or for TI's with S/N 280 and above V883 (fig. 3) (V573, fig. 4).

(2) Turn TI POWER switch to ON.

(3) Connect ac/dc voltmeter (A2) between TI CAL OUT connector and chassis ground, using leads supplied with ac/dc voltmeter and, if necessary, adapter (B 1).

Table 4. Calibrator Accuracy

Test Instrument VOLTS PEAK-TO-PEAK Switch Settings.	Ac/Dc Voltmeter Indications (vdc).	
	Min	Max
50	48.5	51.5
20	19.4	20.6
10	9.7	10.3
5	4.85	5.15
2	1.94	2.06
1	0.97	1.03
.5	0.485	0.515
.2	0.194	0.206
.1	0.097	0.103
.05	0.0485	0.0515

(4) Turn TI VOLTS PEAK-TO-PEAK switch to 100. If ac/dc voltmeter does not indicate between 97 and 103 volts dc, perform b below.

(5) Repeat technique of(4) above for settings and indications listed in table 4. Ac/dc voltmeter. will indicate within limits specified.

(6) Turn TI POWER switch to off (down) and replace vacuum tube removed in (1) above.

(7) Turn TI POWER switch to ON and VOLTS PEAK-TO-PEAK switch to OFF.

b. Adjustments. Adjust CAL ADJ R879 (fig. 3) (CAL. ADJ. R566, fig. 4) for a 100-volt dc indication on ac/dc voltmeter (R).

DEPARTMENT OF THE ARMY TECHNICAL BULLETIN

**CALIBRATION PROCEDURE FOR
OSCILLOSCOPE,
TEKTRONIX TYPES 317 AND RM17**

Headquarters, Department of the Army, Washington, D.C.
30 August 1974

	<i>Paragraph</i>	<i>Page</i>
SECTION I.	IDENTIFICATION AND DESCRIPTION	
	Test instrument identification -----	1 2
	Calibration data card, DA Form 2416-----	2 2
	Reporting of errors -----	3 2
	Calibration description -----	4 2
II.	EQUIPMENT REQUIREMENT FOR OSCILLOSCOPE, TEKTRONIX TYPES 317 AND RM17 (A-LEVEL)	
	Equipment required -----	5 3
	Accessories required -----	6 3
III.	PRELIMINARY OPERATIONS FOR OSCILLOSCOPE, TEKTRONIX TYPES 317 AND RM17 (A-LEVEL)	
	Preliminary instructions -----	7 5
	Equipment setup -----	8 5
IV.	CALIBRATION PROCESS FOR OSCILLOSCOPE, TEKTRONIX TYPES 317 AND RM17 (A-LEVEL)	
	Crt mechanical alinement -----	9 5
	Crt geometry and astigmatism -----	10 6
	Calibrator accuracy -----	11 6
	Vertical dc balance -----	12 7
	Vertical amplifier and preamplifier gain, attenuation, and stability -----	13 8
	Attenuator compensation -----	14 11
	Sweep triggering-----	15 12
	Magnifier gain and registration -----	16 12
	Horizontal amplifier and sweep length -----	17 13
	Sweep timing-----	18 13
	Rise time -----	19 14
	Power supply-----	20 14
	Final procedure -----	21 15
V.	EQUIPMENT REQUIREMENTS FOR OSCILLOSCOPE, TEKTRONIX TYPE 317 (C-LEVEL)	
	Equipment required -----	22 15
	Accessories required -----	23 16
VI.	PRELIMINARY OPERATIONS FOR OSCILLOSCOPE, TEKTRONIX TYPE 317 (C-LEVEL)	
	Preliminary instructions -----	24 17
	Equipment setup -----	25 17

*This bulletin supersedes TB 9-6625-787-50, 8 December 1969, and TB 9-6625-1172-50, 31 May 1968., including all changes.

	<i>Paragraph</i>	<i>Page</i>
VII. CALIBRATION PROCESS FOR OSCILLOSCOPE, TEKTRONIX TYPE 317 (C-LEVEL)		
Calibrator -----	26	17
Crt alinement -----	27	18
Crt astigmatism -----	28	18
Crt geometry -----	29	18
Sweep triggering -----	30	19
Magnifier gain -----	31	20
Horizontal amplifier gain -----	32	20
Sweep length -----	33	20
Magnifier registration -----	34	20
1 16 SEC sweep timing -----	35	20
10 16 SEC/DIV sweep timing -----	36	21
2 16 SEC/DIV linearity -----	37	21
.5 16 SEC/DIV sweep timing -----	38	21
.2 16 SEC/DIV linearity -----	39	21
.04 16 SEC/DIV sweep timing and linearity -----	40	21
Variable attenuator balance -----	41	22
Amplifier gain and attenuation -----	42	23
Attenuator high-frequency compensation -----	43	23
Attenuator input capacitance -----	44	23
Preamplifier low-frequency compensation -----	45	24
Delay line high-frequency response -----	46	24
Amplifier bandwidth -----	47	25
Preamplifier bandwidth -----	48	26
Power supply -----	49	26
Final procedure -----	50	27

SECTION I

IDENTIFICATION AND DESCRIPTION

1. Test Instrument Identification

This bulletin provides instructions for the A-level calibration of Oscilloscope, Tektronix Types 317 and RM17 and C-level calibration of Oscilloscope, Tektronix Type 317. The manufacturer's instruction manuals were used as the prime data source in compiling these instructions. The oscilloscope will be referred to as the "TI" (test instrument) throughout this bulletin.

a. Model Variations. Type RM17 is the rackmounted version of type 317. Wherever difference exists between types, adjustments and parameters for type 317 are listed in parenthesis for A-level calibration.

b. Time and Technique. The time required for this calibration is approximately 3 hours, using the dc and low frequency technique.

2. Calibration Data Card, DA Form 2416.

a. Forms, records, and reports required for calibration personnel at all levels are prescribed by TM 38-750. DA Form 2416 must be annotated

in accordance with TM 38-750 for each calibration performed.

b. Adjustments to be reported on DA Form 2416 are designated (R) at the end of the sentence in which they appear. When adjustments are in tables, the (R) will follow the designated adjustment. Report only those adjustments made and designated with (R).

3. Reporting of Errors

The reporting of errors, omissions, and recommendations for improving this publication by the individual user is encouraged. Reports should be submitted on DA Form 2028, Recommended Changes to Publications, and forwarded direct to Commander, U.S. Army Missile Command, ATTN: AMSMI-MFPA, Redstone Arsenal, AL 35809.

4. Calibration Description

TI parameters and performance specifications which pertain to this calibration are listed in table 1.

Table 1. Calibration Description

Test Instrument Parameters	Performance Specifications
Power input requirements	115 vac $\pm 10\%$ (or 230 vac $\pm 10\%$), 50 to 60 Hz, 200 w
Calibrator: Output Accuracy Waveform ¹	6.05 to 100 v p-p in 11 steps $\pm 3\%$ Square waves at approx 1 kHz
Vertical deflection system: Deflection factor Accuracy Frequency response Input impedance ¹ Rise time	0.01 to 50 v/cm p-p in 12 steps; 0.1 to 50 v/cm dc coupled and 0.01 v/cm to 50 v/cm ac coupled. $\pm 3\%$ Dc to 10 MHz; 0.1 to 50 v/cm, dc coupled; 2 Hz to 10 MHz, 0.1 to 50 v/cm, ac coupled; 2 Hz to 9 MHz, 0.01 to 0.05 v/cm, ac coupled. 1 megohm, 38 pf, direct connection 35 nsec
Horizontal deflection system: Deflection factor ¹ Frequency response Sweep speeds: Time base	Approx 1.3 v/cm Dc to 500 kHz 0.2 u sec/cm to 2 sec/cm, in 22 steps; 5X magnifier extends fastest sweep rate to 0.04 u sec/cm.

¹ This specification is for information only and is not verified in this bulletin.

SECTION II

EQUIPMENT REQUIREMENTS FOR OSCILLOSCOPE, TEKTRONIX TYPES 317 and RM17 (A-LEVEL)

5. Equipment Required

Table 2 identifies the specified equipment used for A-level calibration. This equipment is issued with the secondary transfer calibration standards set and is to be used in performing this procedure. Alternate items may be used by the calibrating activity when the equipment listed in table 2 is not available. The items selected must be verified to perform satisfactorily prior to use and must bear evidence of current calibration. The equipment must meet or exceed the minimum use specifications listed in table 2. The accuracies

listed in table 2 provide a four-to-one ratio between the standard and TI. Where the four-to-one ratio cannot be met, the actual accuracy of the equipment selected is shown in parenthesis.

6. Accessories Required

The accessories listed in table 3 are issued with the secondary transfer calibration standards set and are to be used for A-level calibration. When necessary, these items may be substituted by equivalent items unless specifically prohibited.

Table 2. Minimum Specifications of Equipment Required

Item	Common Name	Minimum Use Specifications	Manufacturer, Model, and Part Number
A1	AC CALIBRATOR	Range: 13.7158 mv rms to 72.826 v rms at 1 kHz. Accuracy: $\pm 0.75\%$	Hewlett-Packard, Model 745A (MIS-10342).
A2	AC/DC VOLTMETER	Range: -153 to +309 vdc Accuracy: $\pm 0.75\%$	Dana, Model 5703-S-2127 (7912606).
A3	AUTOTRANSFORMER	Range: 105 to 125 vac Accuracy: $\pm 0.75\%$	General Radio, Model W10MT3AS3 (7910809).
A4	DC VOLTMETER	Range: -1261 to -1339 vdc Accuracy: $\pm 0.75\%$	Electrical Instruments Service, Model ESV (MIS-10276).
A5	SQUARE-WAVE GENERATOR.	Range: 50 Hz to 1 MHz Rise Time: Less than 35 nsec	Tektronix, Type 106 (MIS-10284).
A6	TIME-MARK GENERATOR	Range: 20 nsec to 1 sec markers. Accuracy: $\pm 0.75\%$	Tektronix, Type 184MOD 146B (7912042-2).

Table 3. Accessories Required

Item	Common Name	Description and Part Number
B1	ADAPTER	BNC plug to double banana posts (7909401)
B2	ADAPTER	BNC jack to UHF plug (10519439)
B3	ADAPTER	UHF jack to BNC plug (8109698)
B4	CABLE	36-in., RG-580/U; BNC plug and double banana plug terminations (7907471).
B5	CABLE	30-in., RG-580/U; BNC plug terminations (7907467)
B6	CAPACITANCE STANDARDIZER.	5 to 80 pf, variable (SKD-4850-44)
B7	LEAD	24-in., No. 18 AWG; single banana plug terminations (red) (7907497).
B8	LEAD	24-in., No. 18 AWG; single banana plug terminations (black) (7907498).
B9	PROBE	Test hook, banana plug to miniature hook (SKC-4850-14)

SECTION III

PRELIMINARY OPERATIONS FOR OSCILLOSCOPE,
TEKTRONIX TYPES 317 AND RM17 (A-LEVEL)

7. Preliminary Instructions

a. The instructions outlined in this section are preparatory to the calibration process. Personnel should become familiar with the appropriate sections before beginning the calibration.

b. Items of equipment used in this procedure are referenced within the text by common name and item identification number as listed in tables 2 and 3. For the identification of equipment referenced by item numbers prefixed with A, see table 2, and for prefix B, see table 3.

WARNING

HIGH VOLTAGE is used during the performance of this calibration. DEATH ON CONTACT may result if personnel fail to observe safety precautions.

8. Equipment Setup

- a. Remove protective cover from TI.
- b. Connect TI to autotransformer (A3).
- c. Connect autotransformer to 115-volt

ac source and adjust controls for 115 volts ac.

d. Position TI controls as listed in (1) through (15) below:

- (1) INTENSITY control to midrange.
- (2) FOCUS control to midrange.
- (3) CALIBRATOR switch to OFF.
- (4) HORIZONTAL DISPLAY switch to NORM.
- (5) TRIGGER SELECTOR switch (black) to

+INT.

- (6) TRIGGER SELECTOR switch (red) to

AUTO.

- (7) TRIGGERING LEVEL control to 0 (zero).
- (8) STABILITY control fully clockwise.
- (9) TIME/DIV switch to .1 MILLISEC.

(10) VARIABLE TIME/DIV control to CALIBRATED.

(11) VERTICAL POSITIONING control to midrange.

(12) HORIZONTAL POSITIONING control to midrange.

- (13) VOLTS/DIV switch to .1.

(14) VARIABLE VOLTS/DIV control to CALIBRATED.

- (15) AC DC switch to AC.

e. Turn POWER switch to ON and allow sufficient time for equipment to warm up and stabilize.

SECTION IV

CALIBRATION PROCESS FOR OSCILLOSCOPE,
TEKTRONIX TYPES 317 AND RM17 (A-LEVEL)**NOTE**

Unless otherwise specified, verify the results of each test and take corrective action whenever the test requirement is not met before continuing with the calibration.

NOTE

When indications specified in paragraphs 9 through 19 are not within tolerance, perform the power supply check prior to making adjustments. After adjustments are made, repeat paragraphs 9 through 19. Do not perform power supply check if all other parameters are within tolerance.

9. Crt Mechanical Alinement

a. Performance Check

(1) Position TI controls as listed in (a) through (c) below:

- (a) SCALE ILLUM control as desired.

(b) INTENSITY and FOCUS controls for sharp trace.

(c) HORIZONTAL POSITION control for start of trace at left edge of graticule.

(2) Adjust VERTICAL POSITION control for start of trace aligned with center horizontal graticule line. If end of trace is not within M small division of center horizontal graticule line, perform b below.

b. Adjustments

WARNING

HIGH VOLTAGE is present in area of crt base; use extreme caution when making the following adjustments.

(1) Loosen crt base clamp and rotate crt with positioning handle for indication as specified in a(2) above.

(2) Tighten crt base clamp and repeat a(2) above.

10. Crt Geometry and Astigmatism

a. Performance Check

(1) Connect time-mark generator (A6) to TI VERTICAL INPUT, using cable (B5) and if necessary, adapter (B2). Adjust time-mark generator for .1 mS marker output.

(2) Adjust TI POSITIONING controls to aline top of markers with top horizontal graticule line and extending across full horizontal range of crt. If markers displayed on crt are not parallel with vertical graticule lines, perform b(1) below.

(3) Reposition TI waveform to display both the baseline and markers. If sharp focus of crt display cannot be obtained by adjusting front panel FOCUS control, perform b(2) below.

b. Adjustments

(1) Adjust R861 (fig. 1) (GEOM ADJ R861, fig. 2) until markers are parallel with vertical graticule line.

(2) Adjust R860 (fig. 1) (ASTIG R856, fig. 2) in conjunction with FOCUS control for sharpest focus of displayed baseline and markers.

11. Calibrator Accuracy

a. Performance Check

(1) Turn TI POWER switch to off (down position) and remove V875 (fig. 3), or for TI's with SIN 280 and above V883 (fig. 3) (V573, fig. 4).

(2) Turn TI POWER switch to ON.

(3) Connect ac/dc voltmeter (A2) between TI CAL OUT connector and chassis ground, using leads supplied with ac/dc voltmeter and, if necessary, adapter (B1).

Table 4. Calibrator Accuracy

Test Instrument VOLTS PEAK-TO-PEAK Switch Settings.	Ac/Dc Voltmeter Indications (vdc).	
	Min	Max
50	48.5	51.5
20	19.4	20.6
10	9.7	10.3
5	4.85	5.15
2	1.94	2.06
1	0.97	1.03
.5	0.485	0.515
.2	0.194	0.206
.1	0.097	0.103
.05	0.0485	0.0515

(4) Turn TI VOLTS PEAK-TO-PEAK switch to 100. If ac/dc voltmeter does not indicate between 97 and 103 volts dc, perform b below.

(5) Repeat technique of (4) above for settings and indications listed in table 4. Ac/dc voltmeter will indicate within limits specified.

(6) Turn TI POWER switch to off (down) and replace vacuum tube removed in (1) above.

(7) Turn TI POWER switch to ON and VOLTS PEAK-TO-PEAK switch to OFF.

b. Adjustments. Adjust CAL ADJ R879 (fig. 3) (CAL. ADJ. R566, fig. 4) for a 100-volt de indication on ac/dc voltmeter (R).

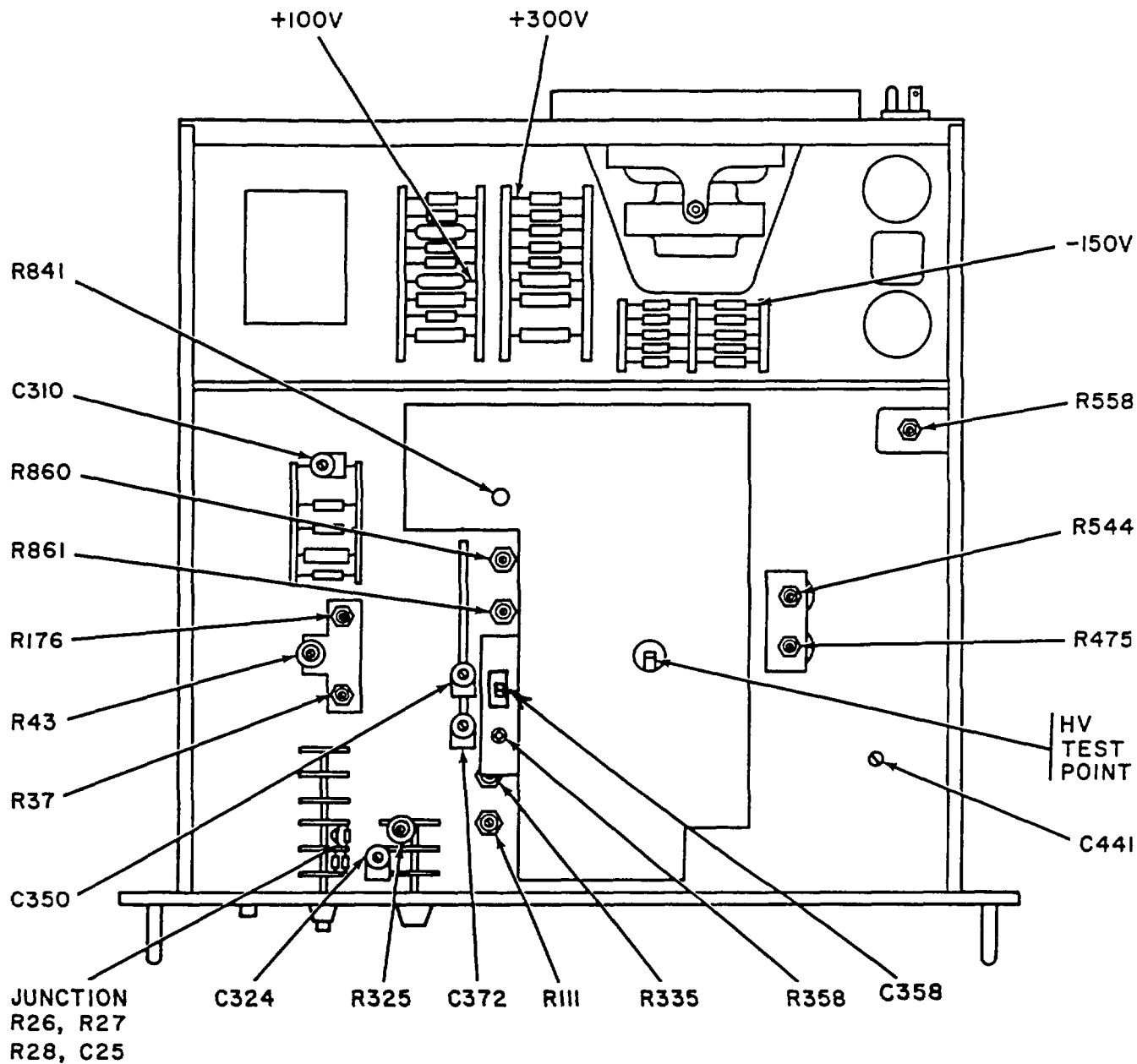

12. Vertical Dc Balance

a. Performance Check

(1) Connect TI VERTICAL INPUT to chassis ground, using lead (B 7), and if necessary, adapter (B1).

(2) Position TI controls as listed in (a) through (c) below:

(a) AC/DC switch to DC.

(b) STABILITY control fully clockwise.

(c) VERTICAL POSITION control to aline trace behind horizontal graticule center line.

(3) Turn VARIABLE VOLTS/DIV control from fully clockwise to fully counterclockwise

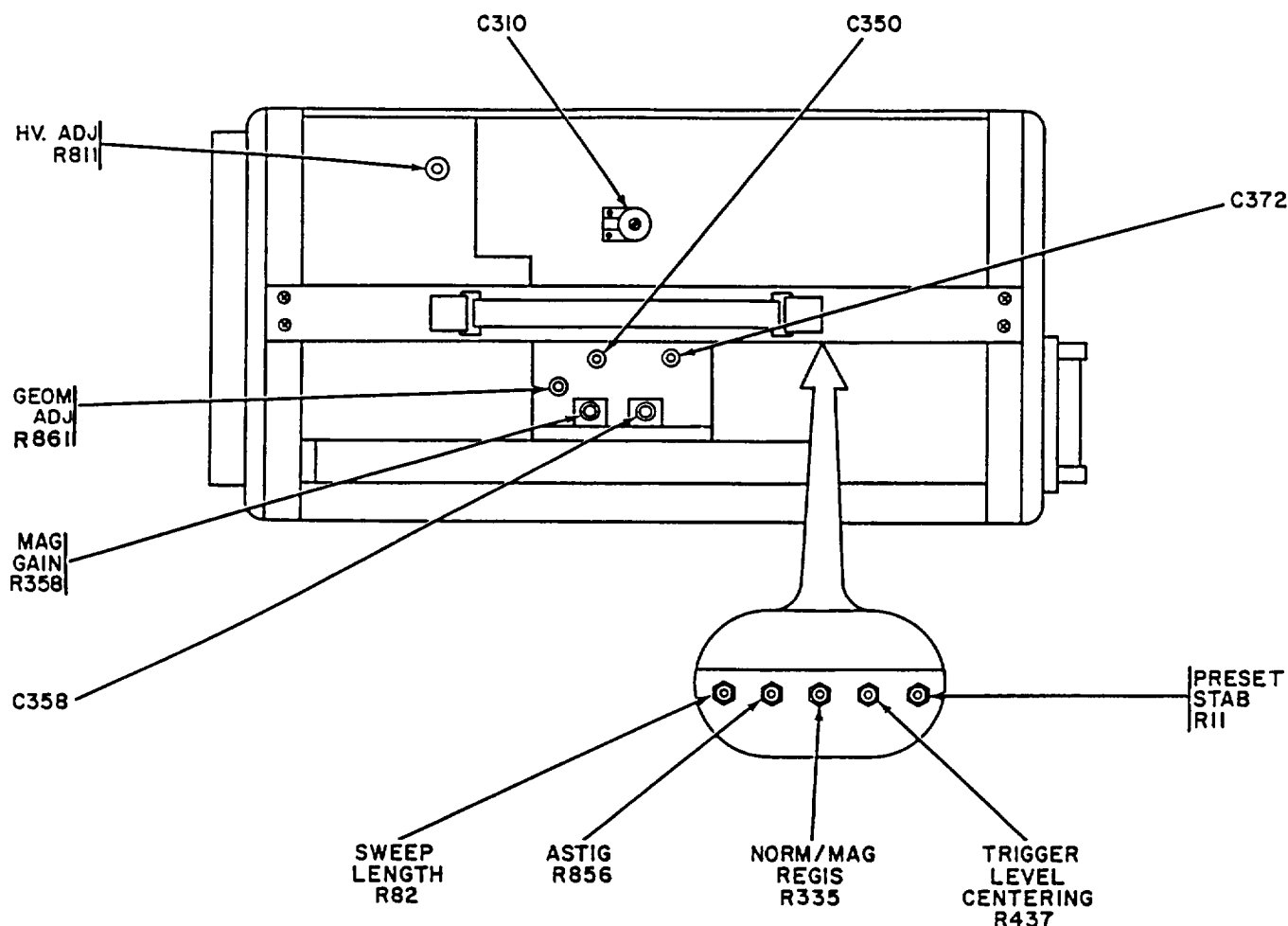

MSC00034

Figure 2. Oscilloscope - top view (type 317).

position. If trace does not remain behind center horizontal graticule line, perform b below.

b. Adjustments. Adjust VARIABLE ATTEN. BAL. (front panel) for minimum vertical movement of trace while turning VARIABLE VOLTS/DIV control throughout its range.

13. Vertical Amplifier and Preamplifier Gain, Attenuation. and Stability

a. Performance Check

(1) Connect ac calibrator (A1) output to T1 VERTICAL INPUT, using cable (B4) and, if necessary, adapter (B2).

(2) Turn TIME/DIV switch to 1 mSEC and VARIABLE VOLTS/DIV switch to CALIBRATED.

(3) Adjust ac calibrator for 1 kHz and amplitude for 4 major divisions of vertical deflection on T1 crt. If ac calibrator does not indicate between 137.158 and 145.642 millivolts rms, perform b(1) below.

(4) Turn VOLTS/DIV switch to .01 and adjust ac calibrator for 4 major divisions of vertical deflection on T1 crt. If ac calibrator does not indicate

between 13.7158 and 14.5642 millivolts rms, perform b(2) below.

(5) Vary autotransformer (A3) between 105 and 125 volts. Ac calibrator will remain between limits specified in (4) above.

(6) Adjust autotransformer for 115 volts.

(7) Repeat technique of (4) above, using settings listed in table 5. Ac calibrator will indicate between limits specified.

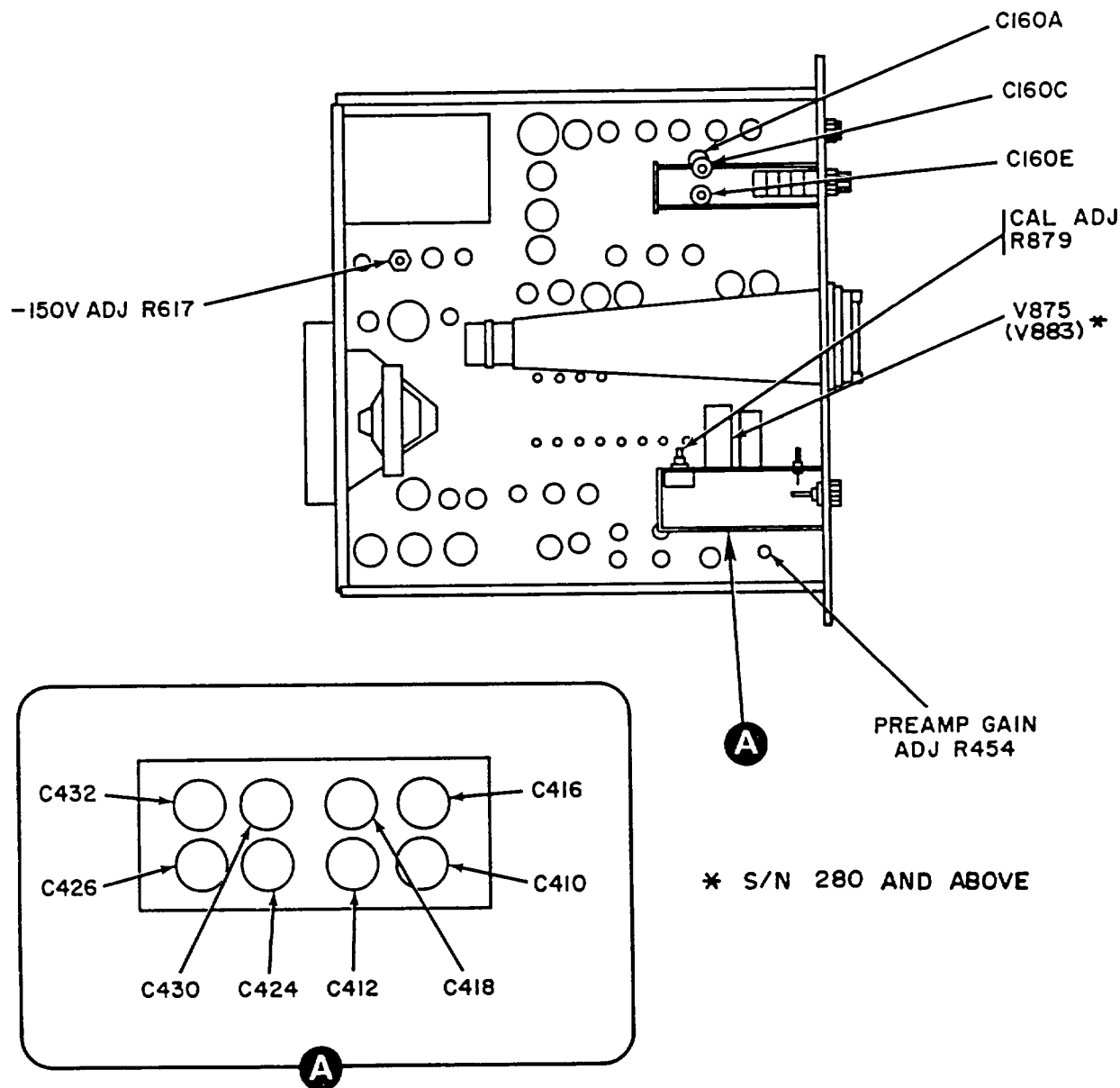

* S/N 280 AND ABOVE

MSC00035

Figure 3. Oscilloscope-top Mew (type RM17).

Table 5. Vertical Amplifier and Preamplifier Gain and Attenuation

Test Instrument VOLTS/DIV Switch Settings.	Ac/Dc Voltmeter Indications (vdc).	
	Min	Max
.02	27.4316 mv	29.1284 mv
.05	68.579 mv	72.821 mv
.2	274.316 mv	291.284 mv
.5	685.79 mv	728.21 mv
1	1.37158 v	1.45642 v
2	2.74316 v	2.91284 v
5	6.8579 v	7.2821 v
10	13.7158 v	14.5642 v
20	27.4316 v	29.1284 v
50	68.579 v	72.821 v

b. Adjustments

(1) Adjust ac calibrator for 141.4 millivolts rms output. Adjust R544 (fig. 1) (GAIN ADJ R244, fig. 5) for 4 major divisions of vertical deflection on crt (R).

(2) Adjust ac calibrator for 14.14 millivolts rms output. Adjust PREAMP GAIN ADJ R454 (fig. 3) (PREAMP GAIN ADJ R154, fig. 5) for 4 major divisions of vertical deflection crt (R).

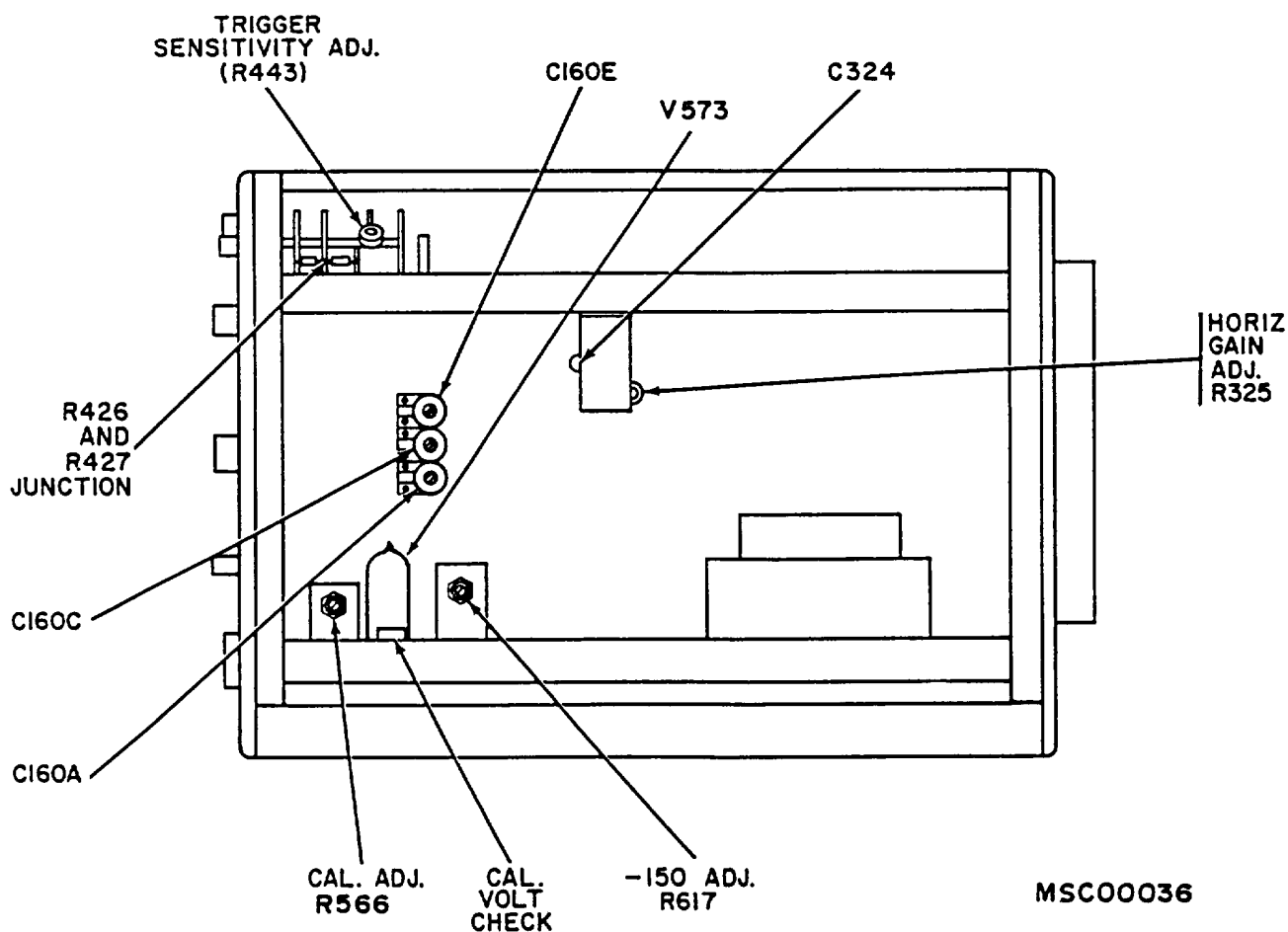

Figure 4. Oscilloscope - right-side view (type 317).

14. Attenuator Compensation

a. Performance Check

(1) Connect square-wave generator (A5) to TI INPUT, using cable and termination supplied with square-wave generator, and adapter and capacitance standardizer (B2 and B6) and, if necessary, adapter (B3).

(2) Turn TI VOLTS/DIV switch to .01 and TIME/DIV switch to .5 MILLISEC.

(3) Adjust square-wave generator for 1 kHz and amplitude for approximately 4 major divisions of vertical display on TI crt.

(4) Adjust capacitance standardizer for optimum square-wave display on TI crt.

(5) Repeat technique of (3) above for each VOLTS/DIV switch setting listed in table 6. If square wave displayed on TI crt does not have flat tops and square corners, perform the appropriate adjustments listed in table 6.

Table 6. Attenuator Compensation Adjustments

Test Instrument VOLTS/DIV Switch Settings.	Adjustments (fig. 3 or 5)	
	Flat Top	Square Corner
.2	C430 (C130) (R)	C432 (C132) (R)
.5	C424 (C124) (R)	C426 (C126) (R)
1	C416 (C116) (R)	C418 (C118) (R)
10	C410 (C110) (R)	C412 (C112) (R)
.02	C441 ¹ (R)	---
.05 ²	R475 ¹ (R175) (R)	---

¹ Refer to figure 1 for location.

² Turn TI TIME/DIV switch to 5 mSEC and adjust square-wave generator to 50 Hz.

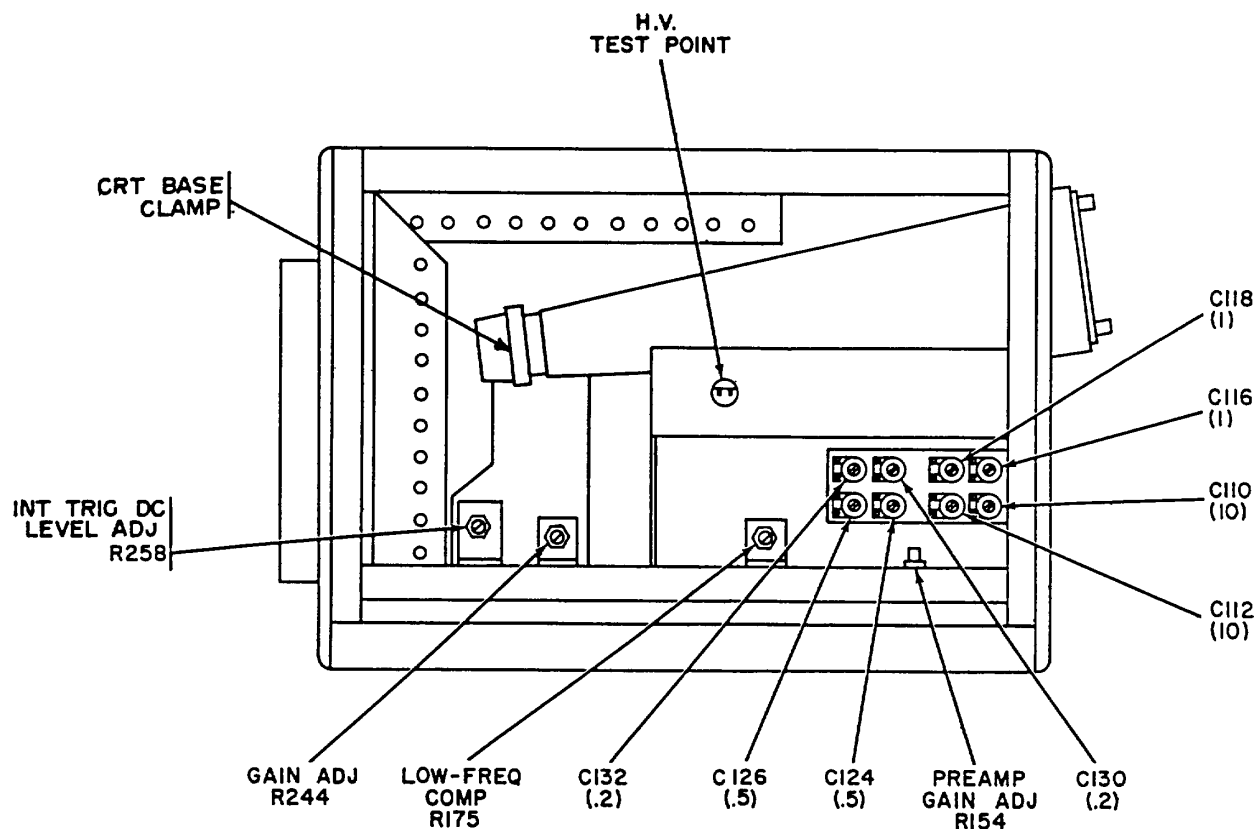

Figure 5. Oscilloscope—left-side view (type 317).

MSC00037

Figure 5. Oscilloscope—left-side view (type 317).

b. *Adjustments.* No further adjustments can be made.

15. Sweep Triggering

a. *Performance Check*

(1) Connect CAL OUT to VERTICAL INPUT, using lead (B7) or cable (B5).

(2) Position TI controls as listed in (a) through (e) below:

(a) TRIGGER SELECTOR switch (red) to AC.

(b) TIME/DIV switch to .5 MILLISEC.

(c) VOLTS/DIV switch to 1.

(d) VOLTS PEAK-TO-PEAK switch to

.5.

(e) STABILITY switch to PRESET.

(3) Connect junction of R26, R27, R28, and C25 (fig. 1) (or R426 and R427, fig. 4) to chassis ground, using probe (B9).

(4) Adjust VOLTS/DIV VARIABLE control for 1 minor division of vertical deflection on TI crt.

(5) Position crt trace on horizontal graticule center line.

(6) Alternately switch TI TRIGGER SELECTOR (black) control back and forth from +INT to -INT. If sweep does not have stable triggering in both +INT and -INT positions, perform 6(1) through (3) below.

(7) Remove short connected in (3) above.

(8) Turn TI TRIGGERING LEVEL control to position where stable triggering occurs in both +INT and -INT positions. If stable triggering does not occur when TRIGGERING LEVEL control is in 0 (zero) position, perform b(4) below.

(9) Turn TI TRIGGERING SELECTOR (red) switch to DC.

(10) It may be necessary to adjust TI VERTICAL POSITIONING control until sweep appears on crt.

(11) Adjust VOLTS/DIV VARIABLE control for 1.5 minor divisions of vertical display on TI crt. If crt display is not positioned at the center horizontal graticule line, while TI TRIGGER SELECTOR (black) switch is turned from +INT to -INT, perform b(5) below.

(12) Turn TI VOLTS PEAK-TO-PEAK switch to OFF.

(13) Remove lead (B7) or cable (B5) connected in (1) above.

(14) Turn TI TRIGGER SELECTOR (red) switch to AUTO. IF stable waveform does not occur, perform b(6) through (8) below.

b. *Adjustments*

(1) Adjust TI TRIGGER LEVEL CENTERING R37 (fig. 1) (R437, fig. 2) until stable triggering is obtained in both +INT and -INT positions.

(2) Reduce amplitude of crt display, using VOLTS/DIV VARIABLE control until display becomes unstable. Adjust R43 (fig. 1) on TI's with S/N 203 and above (TRIGGER SENSITIVITY ADJ. R443, fig. 4) until stable triggering is obtained in both +INT and -INT positions.

(3) Repeat (1) and (2) above until no further adjustments are required.

(4) Loosen setscrew on TRIGGERING LEVEL knob and adjust to 0 (zero) position without turning potentiometer shaft. Tighten setscrew.

NOTE

Do not disturb setting of TRIGGERING LEVEL control established in a(8) above.

(5) Adjust R558 (fig. 1) (INT TRIG DC LEVEL ADJ R258, fig. 5) in conjunction with VERTICAL POSITIONING control until sweep is positioned at center horizontal graticule line as TRIGGER SELECTOR (black) switch is turned from -INT to +INT.

(6) Turn R111 (fig. 1) (PRESET STAB R11, fig. 2) fully counterclockwise; then, turn slowly clockwise until trace appears on TI crt. Note position of R111 (R11) shaft.

(7) Continue turning R111 (R11) clockwise until trace brightens. Note position of R111 (R11) shaft.

(8) Adjust R111 (R11) to a position that is midway between positions noted in (6) and (7) above.

16. Magnifier Gain and Registration

a. *Performance Check*

(1) Connect time-mark generator (A6) to TI VERTICAL INPUT, using cable (B5) and, if necessary, adapter (B2). Set time-mark generator to 1 mS markers.

(2) Position TI controls as listed in (a) through (j) below:

(a) VARIABLE VOLTS/DIV control to CALIBRATED.

(b) AC/DC switch to AC.

(c) TRIGGER SELECTOR (red) switch to AC.

(d) TRIGGER SELECTOR (black) switch to +INT.

(e) HORIZONTAL DISPLAY switch to MAG.

(f) TIME/DIV switch to 5 MILLISEC.

(g) STABILITY and TRIGGERING LEVEL controls for a stable display.

(h) VERTICAL POSITIONING control to center trace vertically.

(i) HORIZONTAL POSITIONING control

for second marker alined behind second vertical graticule line. If 10th marker is not displayed within 1.5 minor divisions of 10th vertical graticule line, perform *b(1)* below.

(3) Adjust HORIZONTAL POSITIONING control to aline first marker behind center vertical graticule line.

(4) Turn HORIZONTAL DISPLAY switch to NORM. If first marker does not remain alined behind center vertical graticule line, perform *b(2)* and (3) below.

b. Adjustments

(1) Adjust R358 (fig. 1) (MAG GAIN R358, fig. 2) for one marker per major division on TI crt (R).

(2) Adjust R335 (fig. 1) (NORM/MAG REGIS R335, fig. 2) to aline first marker behind center vertical graticule line (R).

(3) Repeat *a(2)(e)*, (3), (4), and *b(2)* above until indication specified in *a(4)* above is obtained.

17. Horizontal Amplifier and Sweep Length

a. Performance Check

(1) Adjust time-mark generator (A6) for .1 mS markers.

(2) Turn TIME/DIV switch on TI to .1 MILLISEC.

(3) Adjust TI HORIZONTAL POSITIONING control to aline second marker behind second vertical graticule line. If 10th marker is not displayed within ± 1.5 minor divisions of 10th vertical graticule line, perform *b(1)* below.

(4) Adjust time-mark generator for 50 μ SEC markers.

(5) Adjust TI HORIZONTAL POSITIONING control to aline first marker behind first vertical graticule line. If trace on TI crt does not extend one marker past 11th graticule line, perform *b(2)* below.

b. Adjustments

(1) Adjust R325 (fig. 1) (HORIZ GAIN ADJ. R325, fig. 4) until one time marker per centimeter is displayed between second and 10th vertical graticule lines (R).

(2) Adjust R176 (fig. 1) (SWEEP LENGTH R82, fig. 2) for sweep length extending one marker past right edge of graticule.

18. Sweep Timing

a. Performance Check

(1) Adjust time-mark generator (A6) to 10 μ SEC markers.

(2) Turn TI TIME/DIV switch to .1 MILLISEC and HORIZONTAL DISPLAY switch to MAG.

(3) Position first marker behind center vertical graticule line.

(4) Turn TI TIME/DIV switch to 50 μ SEC. If first marker does not remain behind center vertical graticule line, perform *b(1)* and (2) below.

(5) Turn TI TIME/DIV switch to 5 μ SEC and adjust time-mark generator for 1 μ SEC markers.

(6) Adjust TI HORIZONTAL POSITIONING

Table 7. Sweep Timing

Test Instrument TIME/DIV Switch Settings.	Time-Mark Generator Settings.	Markers Per cm.	Adjustments (fig. 3 or 4).
1 μ SEC	1 μ SEC	1	---
10 μ SEC	10 μ SEC	1	C160E (R)
20 μ SEC	10 μ SEC	2	---
50 μ SEC	50 μ SEC	1	---
.2 μ SEC ¹	.1 μ SEC	2	2
.2 μ SEC ^{1 3}	.1 μ SEC	4/10 cm	4
2 μ SEC	.1 μ SEC	2	5
.5 μ SEC	.5 μ SEC	1	C160A (R)
.1 MILLISEC	.1 mS	1	---
.2 MILLISEC	.1 mS	2	---
.5 MILLISEC	.5 mS	1	---
1 MILLISEC	.1 mS	1	---
2 MILLISEC	.1 mS	2	---

See footnotes at end of table.

Table 7. Sweep Timing-Continued

Test Instrument TIME/DIV Switch Settings.	Time-Mark Generator Settings.	Markers Per cm.	Adjustments (fig. 3 or 4).
5 MILLISEC	5 mS	1	---
10 MILLISEC	10 mS	1	---
20 MILLISEC	10 mS	2	---
50 MILLISEC	50 mS	1	---
.1 SEC	.1 S	1	---
.2 SEC	.1 S	2	---
.5 SEC	.5 S	1	---
1 SEC	1 S	1	---
2 SEC	1 S	2	---

¹ Turn TRIGGER SELECTOR switch (red) from AC to HF SYNC for this check only.

² If TI crt does not display 2 markers per cm, adjust C324 (fig. 1 or 4) (R). Then, adjust C358 (fig. 1 or 2) for the most linear display over the first few divisions (R). If necessary, repeat adjustment of C324 and C358 to obtain optimum display.

³ Turn HORIZONTAL DISPLAY switch to MAG for this check only.

⁴ Adjust C350 and C372 (fig. 1 or 2) in equal Increments until four cycles of sine wave are within 10 major divisions of horizontal deflection (R).

⁵ If an out-of-tolerance indication is observed, repeat footnote 2 above.

control to align second marker behind second vertical graticule line. If TI crt does not display one marker per centimeter, perform *b*(3) below.

(7) Turn TI HORIZONTAL DISPLAY switch to NORM and repeat technique of (5) and (6) above for TI TIME/DIV switch and time-mark generator settings listed in table 7. If TI crt does not display markers as specified, perform the appropriate adjustment listed in table 7.

b. Adjustments

(1) Adjust C310 (fig. 1 or 2) until first marker remains behind center vertical graticule line (R).

(2) Repeat *a*(2) through (4) above.

(3) Adjust C160C (fig. 3 or 4) for one marker per centimeter on TI crt (R).

NOTE

Due to interaction between C310 and C160C, repeat *a*(1) through (6) above for optimum conditions.

19. Rise Time

a. Performance Check

(1) Connect square-wave generator (A5) +OUTPUT to TI VERTICAL INPUT, using cable and termination supplied with square-wave generator and, if necessary, adapter (B2).

(2) Position TI controls as listed in (a) through (d) below:

(a) TIME/DIV switch to .2 ,SEC.

(b) HORIZONTAL DISPLAY switch to

MAG.

(c) VOLTS/DIV switch to .1.

(d) AC/DC switch to DC.

(3) Adjust square-wave generator for 1 MHz and amplitude for 4 divisions of vertical deflection on TI crt.

(4) Measure rise time, using standard risetime technique. Rise time will not exceed 35 nanoseconds.

b. Adjustments. No adjustments can be made.

20. Power Supply

NOTE

Do not perform power supply check if all other parameters are within tolerance.

a. Performance Check

(1) Connect ac/dc voltmeter (A2) between -150V test point (fig. 1 or 6) and chassis ground. If ac/dc voltmeter does not indicate between -147 and -153 volts dc, perform *b*(1) below.

(2) Repeat technique of (1) above, using test points listed in table 8. Ac/dc voltmeter will indicate within limits specified.

Table 8. Low-Voltage Power Supply

Test Instrument Test Points (fig. 1 or 6).	Ac/Dc Voltmeter Indications (v)	
	Min	Max
+100 V	+97	+103
+300 V	+291	+309

(3) Connect dc voltmeter (A4) between HV test point (fig. 1 or 5) and chassis ground. If dc voltmeter does not indicate between -1261 and -1339 volts dc, perform b(2) below.

b. Adjustments

(1) Adjust -150 ADJ. R617 (fig. 3) (-150 ADJ. R617, fig. 4) for a -150-volt indication on ac/dc voltmeter (R).

(2) Adjust R841 (fig. 1) (H.V. ADJ. R811,

fig. 2) for a -1300-volt dc indication on dc voltmeter (R).

21. Final Procedure

a. Deenergize and disconnect all equipment and replace TI within protective cover.

b. In accordance with TM 38-750, annotate and affix DA Label 80 (U.S. Army Calibration System). When the TI cannot be adjusted within tolerance, annotate and affix DA Form 2417 (Unserviceable or Limited Use tag).

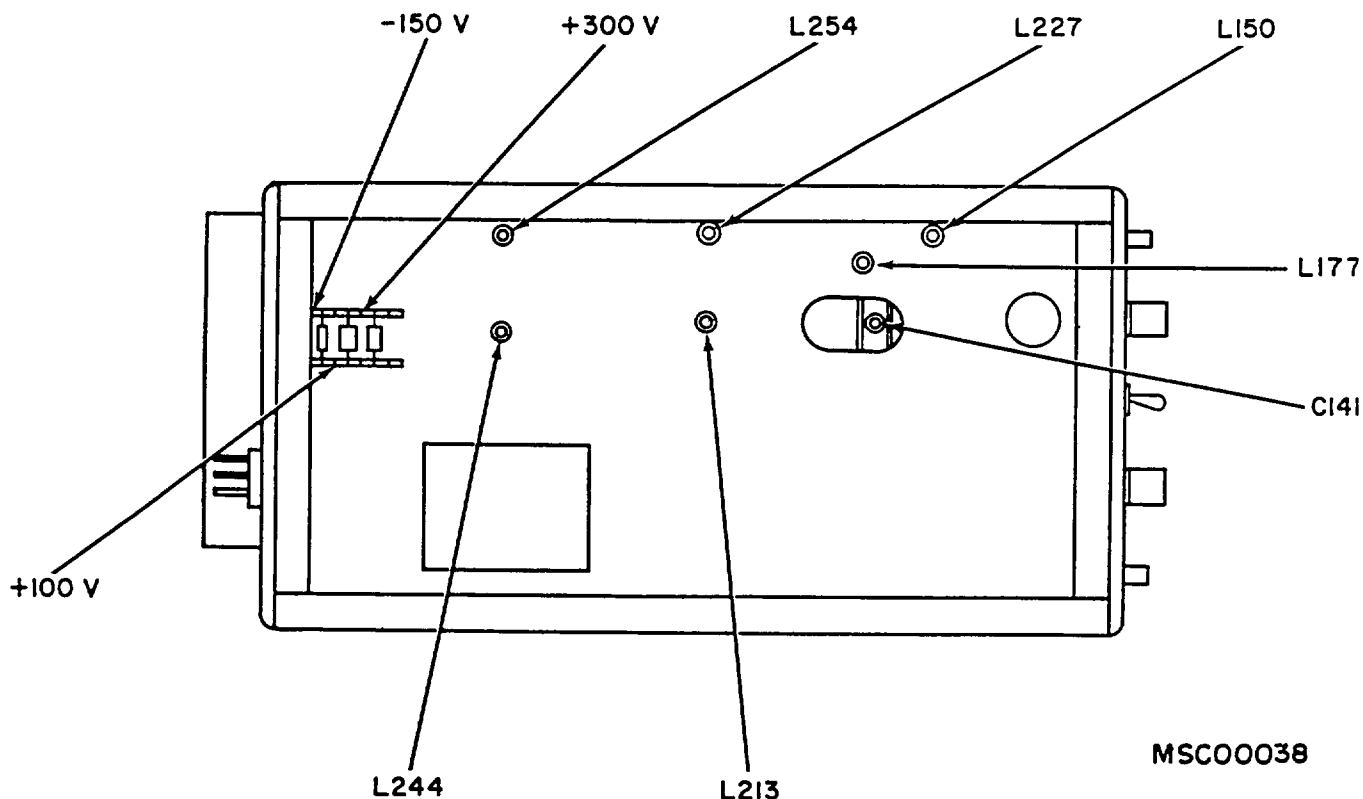

Figure 6. Oscilloscope-bottom view (type 317).

**SECTION V
EQUIPMENT REQUIREMENTS FOR OSCILLOSCOPE, TEKTRONIX TYPE 317 (C-LEVEL)**

22. Equipment Required

a. Minimum use specifications are the principal parameters required for performance of C-level calibration, and are included to assist in the selection of alternate equipment. Satisfactory performance of alternate items must be verified prior to use. All applicable equipment must bear evidence of current calibration.

b. The instruments used for C-level calibration were selected from those known to be available in AN/TSM-55(V) 2 and TOE 29-134. The listing by make or model number carries no implication of

preference, recommendations, or approval by the Department of Defense for use by other agencies. It is recognized that equivalent equipment produced by other manufacturers may be capable of equally satisfactory performance in the procedure.

c. Items of equipment used for C-level calibration are referenced within the text by common name and item identification number as listed in table 9. For the identification of equipment referenced by item numbers prefixed with A, see table 9.

23. Accessories Required

The accessories used for C-level calibration were selected from those known to be available in AN/TSM-55(V)2 and TOE 29-134 and are to be used in this calibration procedure. When necessary, these items may be substituted by equivalent items unless

specifically prohibited. Accessory items used in this procedure are referenced within the text by common name and item identification number as listed in table 10. For the identification of accessories referenced by item numbers prefixed with B, see table 10.

Table 9. Minimum Specifications of Equipment Required

Item	Common Name	Minimum Use Specifications.	Manufacturer and Model Number.
A1	AUTOTRANSFORMER	Range: 105 to 125 vac Accuracy: $\pm 3\%$	General Radio, Model W10MT3A (TF-510/U).
A2	METER CALIBRATOR.	Range: 350 mw to 36 vac, 400 Hz. Accuracy: $\pm 1\%$	John Fluke, Model 760A (TS-2734/U).
A3	MULTIMETER	Range: -1339 to +309 vdc Accuracy: $\pm 0.5\%$	J-Omega, Model 217A (ME-333/U).
A4	RATIO TRANSFORMER.	Range: 0 to 36 vac at 400 Hz Ratio: .0194 to .776 to 1 Accuracy: $\pm 0.3\%$	Gertsch, Model RT-60 (TS-515/U).
A5	SIGNAL GENERATOR.	Range: 50 kHz to 10 MHz Accuracy: $\pm 1\%$	Tektronix, Type 191 (AN/USM-272).
A6	SQUARE-WAVE GENERATOR.	Range: 1 to 400 kHz Rise time: Less than 0.020 μ sec.	Fairchild, Model 791 (AN/USM-256).
A7	TIME-MARK GENERATOR.	Range: 1 sec to 50 nsec markers. Accuracy: $\pm 1\%$	Tektronix, Type 184 (AN/USM-271).

Table 10. Accessories Required.

Item	Common Name	Manufacturer, Model Number, and Description
B1	ADAPTER ¹	H. H. Smith, Model 301; banana jack to alligator clip
B2	ADAPTER ¹	Pomona Electronics, Model 1296 (UG-1888/U); binding post to BNC plug.
B3	ADAPTER	Pomona Electronics, Model 201A/U; BNC jack to N plug
B4	CABLE ¹	Pomona Electronics, Model 2241-C-36 (CG-3572/U); BNC plug to red and black banana plugs.
B5	LEAD ¹	Pomona Electronics, Model B-24 (red); 24-in., single banana plug to single banana plug.
B6	LEAD ¹	Pomona Electronics, Model B36 (black); 36-in., single banana plug to single banana plug.
B7	LEAD ¹	Pomona Electronics, Model B-36 (red); 36-in., single banana plug to single banana plug.

¹ Two required.

SECTION VI

PRELIMINARY OPERATIONS FOR
OSCILLOSCOPE, TEKTRONIX TYPE 317 (C-LEVEL)

24. Preliminary Instructions

The instructions outlined in this paragraph are preparatory to the calibration process. Personnel should become familiar with the applicable sections of this bulletin before beginning the calibration.

WARNING

HIGH VOLTAGE is used during the performance of this calibration. DEATH ON CONTACT may result if personnel fail to observe safety precaution.

CAUTION

To avoid possible burning of crt screen, keep intensity control set to a normal level and never allow a bright spot to remain in the same position for lengthy periods of time.

NOTE

Unless otherwise specified, verify the results of each test and take corrective action whenever the test requirement is not met before continuing with the calibration.

NOTE

When indications specified in paragraphs 26 through 48 are not within tolerance, perform the power supply check prior to making adjustments. After adjustments are made, repeat paragraph 26 through 48. Do not perform power supply check if all other parameters are within tolerance.

25. Equipment Setup

- a. Energize equipment and allow sufficient time for equipment to warm up and stabilize.
- b. Adjust autotransformer (A1) output voltage control to minimum.
- c. Connect TI power cord to autotransformer.
- d. Adjust autotransformer output voltage control for a meter indication of 115 volts ac.
- e. Turn TI INTENSITY control fully counterclockwise.
- f. Position TI controls as follows:
 - (1) TRIGGER SELECTOR (black) switch to +INT.
 - (2) TRIGGER SELECTOR (red) switch to AC.
 - (3) STABILITY control fully counterclockwise, but not PRESET.
 - (4) TRIGGER LEVEL control to 0 (zero).
 - (5) TIME/DIV switch to .5 MILLISEC.
 - (6) VARIABLE control to CALIBRATED.
 - (7) HORIZ DISPLAY switch to NORM.
 - (8) POSITIONING VERTICAL control to midrange.
 - (9) POSITIONING HORIZONTAL control to midrange.
 - (10) VOLTS/DIV switch to 1.
 - (11) VARIABLE VOLTS/DIV switch to CALIBRATE.
 - (12) AC-DC switch to AC.
 - (13) CALIBRATOR VOLTS PEAK-TO-PEAK switch to 100.

SECTION VII

CALIBRATION PROCESS FOR OSCILLOSCOPE,
TEKTRONIX TYPE 317 (C-LEVEL)

26. Calibrator

a. Performance Check

- (1) Remove tube V573 (fig. 4) from TI.
- (2) Connect multimeter (A3) between TI

CALIBRATOR CAL OUT connector and chassis ground, using leads (B6 and B7).
(3) Set TI CALIBRATOR VOLTS PEAK-TO-PEAK switch to positions listed in table 11. If multimeter does not indicate within limits specified, perform b below.

Table 11. Calibrator Output

Test Instrument CALIBRATOR VOLTS PEAK-TO-PEAK Switch Settings.	Multimeter Indications (volts).	
	Min	Max
100 ¹	97.0	103.0

¹ See footnote at end of table

Table 11. Calibrator Output-Continued

Test Instrument CALIBRATOR VOLTS PEAK-TO-PEAK Switch Settings.	Multimeter Indications (volts).	
	Min	Max
50	48.5	51.5
20	19.4	20.6
10	9.70	10.30
5	4.85	5.15
2	1.94	2.06
1	0.970	1.030
.5	0.485	0.515
.2	0.194	0.206
.1	0.0970	0.1030
.05	0.0485	0.0515

¹ Adjust autotransformer output voltage control for 105, 125, and 115 volts ac.

- (4) Disconnect equipment.
- (5) Install tube V573 into TI.

b. Adjustments

- (1) Set TI CALIBRATOR VOLTS PEAK-TO-PEAK switch to 100.
- (2) Adjust TI CAL ADJ R566 (fig. 4) for multimeter indication of 100.0 volts ac (R).

27. Crt Alinement

a. Performance Check

- (1) Position TI controls as follows:

- (a) TIME BASE STABILITY control fully clockwise.
- (b) INTENSITY control for TI crt display.
- (c) POSITION VERTICAL control to position TI crt display at center horizontal division line.

- (2) If TI crt display does not aline parallel to center horizontal division line, perform b below.

b. Adjustments

WARNING

HIGH VOLTAGE is present in area of crt base; use extreme caution when making the following adjustments.

- (1) Loosen screw on TI crt base clamp (fig. 5) and turn TI crt to aline trace parallel with center horizontal division line.
- (2) Tighten TI crt base clamp.

28. Crt Astigmatism

a. Performance Check

- (1) Connect TI CALIBRATOR CAL OUT

connector to VERTICAL INPUT connector, using lead (B5).

- (2) Position TI controls as follows:

(a) TIME BASE TRIGGER SELECTOR (red) switch to AUTO.

(b) TIME BASE TIME/DIV switch for TI crt display of 5 cycles.

(c) CALIBRATOR VOLTS PEAK-TO-PEAK switch to 5.

(3) Adjust TI INTENSITY and FOCUS controls for TI crt display of optimum focus. If TI crt display is not evenly focused throughout the length of display, perform b below.

- (4) Disconnect lead (B5).

b. Adjustments. Adjust TI ASTIG R856 (fig. 2) for crt display with even focus throughout the length of display.

29. Crt Geometry

a. Performance Check

(1) Connect time-mark generator (A7) to TI VERTICAL INPUT, using cable (B4). Adjust time-mark generator for 0.1 mS markers.

- (2) Position TI controls as follows:

(a) VERTICAL VOLTS/DIV switch to .2.

(b) TIME BASE TIME/DIV switch to .2 MILLISEC.

(c) POSITIONING VERTICAL control to position top and bottom of display to top and bottom division lines.

(3) If TI crt does not display straight vertical division lines as shown in figure 7, perform b below.

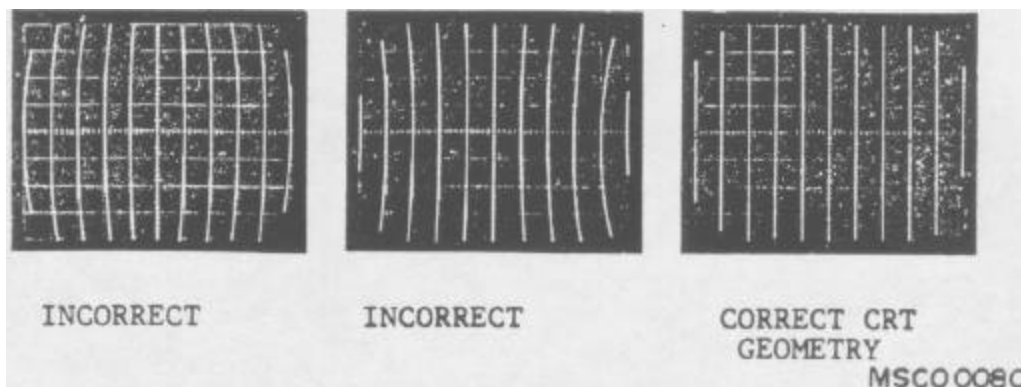

Figure 7. Crt geometry waveform.

(4) Disconnect equipment.

b. Adjustments. Adjust TI GEOM ADJ R861 (fig. 2) for TI crt display of straight vertical lines parallel to the vertical division lines, as shown in figure 7.

30. Sweep Triggering

a. Performance Check

(1) Connect TI CAL OUT to TI INPUT, using lead (B7) and, if necessary, two adapters (B2).

(2) Position TI controls as follows:

(a) TRIGGER SELECTOR switch (red)

to AC.

(b) TIME/DIV switch to .5 MILLISEC.

(c) VOLTS/DIV switch to 1.

(d) VOLTS PEAK-TO-PEAK switch to

.5.

(e) STABILITY SWITCH TO PRESET.

(3) Connect junction of R426 and R427 (fig. 4) to chassis ground, using lead (B5) and two adapters (B1).

(4) Adjust VOLTS/DIV VARIABLE control for 1 minor division of vertical deflection on TI crt.

(5) Position crt trace on horizontal graticule center line.

(6) Alternately switch TI TRIGGER SELECTOR (black) control back and forth from +INT to -INT. If sweep does not have stable triggering in both +INT and -INT positions, perform b(1) through (3) below.

(7) Remove short connected in (3) above.

(8) Turn TI TRIGGERING LEVEL control to position where stable triggering occurs in both +INT and -INT positions. If stable triggering does not occur when TRIGGERING LEVEL control is in 0 (zero) position, perform b(4) below.

(9) Turn TI TRIGGERING SELECTOR (red) switch to DC.

(10) It may be necessary to adjust TI VERTI-

CAL POSITIONING control until sweep appears on crt.

(11) Adjust VOLTS/DIV VARIABLE control for 1.5 minor divisions of vertical display on TI crt. If crt display is not positioned at the center horizontal graticule line, while TI TRIGGER SELECTOR (black) switch is turned from +INT to -INT, perform b(5) below.

(12) Turn TI VOLTS PEAK-TO-PEAK switch to OFF.

(13) Remove lead and adapters connected in (1) above.

(14) Turn TI TRIGGER SELECTOR (red) switch to AUTO. If stable waveform does not occur, perform b(6) through (8) below.

b. Adjustments

(1) Adjust TI TRIGGER LEVEL CENTERING R437 (fig. 2) until stable triggering is obtained in both +INT and -INT positions.

(2) Reduce amplitude of crt display, using VOLTS/DIV VARIABLE control until display becomes unstable. Adjust TRIGGER SENSITIVITY ADJ R443 (fig. 4) until stable triggering is obtained in both +INT and -INT positions.

(3) Repeat (1) and (2) above until no further adjustments are required.

(4) Loosen setscrew on TRIGGERING LEVEL knob and adjust to 0 (zero) position without turning potentiometer shaft. Tighten setscrew.

NOTE

Do not disturb setting of TRIGGERING LEVEL control established in a(8) above.

(5) Adjust INT TRIG DC LEVEL ADJ R258 (fig. 5) in conjunction with VERTICAL POSITIONING control until sweep is positioned at center horizontal graticule line as TRIGGER SELECTOR (black) switch is turned from -INT to +INT.

(6) Turn TI PRESET STAB R11 (fig. 2) fully counterclockwise; then, turn slowly clockwise until grace appears on TI crt. Note position of R11 shaft.

(7) Continue turning R11 clockwise until trace brightens. Note position of R11 shaft.

(8) Adjust R11 to a position midway between positions noted in (6) and (7) above.

31. Magnifier Gain

a. Performance Check

(1) Position TI controls as follows:

(a) TRIGGER SELECTOR (black) switch to +INT.

(b) TRIGGER SELECTOR (red) switch to AC.

(c) HORIZONTAL DISPLAY switch to MAG.

(d) TRIGGERING LEVEL control to 0 (zero).

(e) STABILITY control to PRESET.

(f) TIME/DIV switch to 1 MILLISEC.

(g) TIME/DIV VARIABLE control to

CALIBRATED.

(2) Connect time-mark generator (A7) to TI VERTICAL INPUT connector, using cable (B4). Adjust time-mark generator for .1 mS marker output.

(3) Adjust TI VOLTS/DIV controls for TI crt display of 2 divisions. Center display on TI crt with POSITIONING VERTICAL control.

(4) Adjust TI POSITIONING HORIZONTAL control for a marker aligned with first vertical division line. If TI crt does not display 2 markers per division and the 16th marker from first division line is not within -2.5 minor divisions of the ninth division line, perform b below.

b. Adjustments.

(1) Adjust TI POSITIONING HORIZONTAL control for TI crt display of marker aligned with first division vertical line.

(2) Adjust TI MAG GAIN R358 (fig. 2) for TI crt display with marker from first division line aligned with ninth vertical division line (R).

32. Horizontal Amplifier Gain

a. Performance Check

(1) Set TI TIME/DIV switch to .1 MILLISEC and HORIZ DISPLAY switch to NORM.

(2) Adjust TI POSITIONING HORIZONTAL control for a crt display of second marker at first vertical division line. If TI crt does not display the 10th marker within -1.5 minor divisions of the ninth vertical division line, perform b below.

b. *Adjustments.* Adjust TI HORIZ GAIN ADJ R325 (fig. 4) for TI crt display with 10th marker aligned with ninth vertical division line (R).

33. Sweep Length

a. *Performance Check.* Turn TI STABILITY and TRIGGERING LEVEL controls fully clockwise. If TI crt does not display a trace 10.5 divisions in length, perform b below.

b. *Adjustments.* Adjust TI SWEEP LENGTH R82 (fig. 2) for TI crt display of 10.5 divisions.

34. Magnifier Registration

a. Performance Check

(1) Position TI controls as follows:

(a) STABILITY control to PRESET.

(b) TRIGGER SELECTOR (red) switch to AUTO.

(c) HORIZ DISPLAY switch to MAG.

(2) Adjust POSITIONING HORIZONTAL control for TI crt display of first marker at center vertical division line.

(3) Set TI HORIZ DISPLAY switch to NORM. If TI crt display shifts horizontally, perform b below.

b. *Adjustments.* Adjust TI NORM/MAG REGIS R335 (fig. 2) for no horizontal shift in TI crt display as TI HORIZ DISPLAY switch is alternately set to MAG and NORM.

35. 1 ~~ms~~ SEC Sweep Timing

a. Performance Check

(1) Position TI controls as follows:

(a) TIME/DIV (black) switch to 5 ASEC.

(b) HORIZ DISPLAY switch to MAG.

(2) Adjust time-mark generator (A7) controls for 1 AS marker output.

(3) Adjust TI POSITIONING HORIZONTAL control for TI crt display of last 10 markers with a marker aligned on first vertical division line. If crt does not display 1 marker per division and eighth marker from first division line is not within -1.5 minor divisions of ninth vertical division line, perform b(1) and (2) below.

(4) Adjust TI POSITIONING HORIZONTAL control for TI crt display of first ten markers. If crt does not display 1 marker per division, and eighth marker from first division line is not within 1.5 minor divisions of ninth vertical division line, perform b(3) and (4) below.

b. Adjustments

(1) Repeat a(3) above.

(2) Adjust TI C160C (fig. 4) for TI crt display of 1 marker per division and ninth marker, from first division line, aligned with ninth vertical division line (R).

(3) Adjust C310 (fig. 2) for TI crt display of first 10 markers alined with vertical division lines (R).

(4) Repeat performance check.

36. 10 μ SEC/DIV Sweep Timing

a. Performance Check

(1) Set TI HORIZ DISPLAY switch to NORM and TIME/DIV switch to 10 ASEC.

(2) Adjust time-mark generator (A7) controls for 10 μ markers.

(3) Adjust TI POSITIONING HORIZONTAL control for TI crt display of second marker alined with first vertical division line. If TI crt does not display 1 marker per division and 10th marker is not within ± 1.5 minor divisions of ninth vertical division line, perform b below.

b. Adjustments. Adjust C160E (fig. 4) for crt display of 1 marker per division and 10th marker alined with ninth division vertical line (R).

37. 2 μ SEC/DIV Linearity

a. Performance Check

(1) Set TI TIME/DIV switch to 2 μ SEC.

(2) Adjust time-mark generator (A7) for 1 μ marker output. If TI crt does not display 2 markers per division and the position of markers within the first 2 divisions are not the same as the remaining divisions, perform b below.

b. Adjustments. Adjust C324 (fig. 4) for 2 markers per division (R).

38. .5 μ SEC/DIV Sweep Timing

a. Performance Check

(1) Set TI TIME/DIV switch to .5 μ SEC.

(2) Set TI TRIGGER SELECTOR (red) switch to AC.

(3) Adjust time-mark generator (A7) for .5 μ marker output.

(4) Adjust TI TIME BASE STABILITY and TIME BASE TRIGGERING LEVEL controls for stable TI crt display.

(5) Adjust TI POSITIONING HORIZONTAL control to aline second marker with first division vertical line. If TI crt does not display 1 marker per division and 10th marker is not within ± 1.5 minor divisions of ninth vertical division line, perform b below.

b. Adjustments. Adjust C160A (fig. 4) for crt display of 1 marker per division and 10th marker alined with ninth vertical division line (R).

39. .2 μ SEC/DIV Linearity

a. Performance Check

(1) Position TI controls as follows:

(a) TRIGGER SELECTOR (red) switch to HF SYNC.

(b) TRIGGER SELECTOR (black) switch to +INT.

(c) HORIZ DISPLAY switch to NORM.

(d) TIME/DIV switch to .2 ,SEC.

(e) VARIABLE TIME/DIV control to CALIBRATED.

(f) POSITIONING VERTICAL control to midrange.

(g) POSITIONING HORIZONTAL control to midrange.

(2) Adjust time-mark generator (A7) for .1 μ marker output.

(3) Adjust TI VOLTS/DIV and STABILITY controls for stable display of 2 divisions on TI crt. If crt does not display 2 markers per division and is not linear, perform b below.

b. Adjustments

(1) Adjust C358 (fig. 2) for crt display of 2 markers per division and best linearity (R).

(2) If C358 will not adjust for proper timing and linearity, repeat 2 ,SEC/DIV linearity, paragraph 37 above and .2 μ /SEC/DIV linearity, paragraph 39 above.

40. .04 μ SEC/DIV Sweep Timing and Linearity

a. Performance Check

(1) Connect time-mark generator (A7) TRIGGER OUTPUT to TI TRIGGER INPUT, using cable (B4).

(2) Adjust time-mark generator for .1 μ markers and 1 μ trigger output.

(3) Position TI controls as follows:

(a) HORIZONTAL DISPLAY switch to MAG.

(b) TRIGGER SELECTOR (black) switch to +INT.

(4) Adjust VOLTS/DIV and STABILITY controls for crt display of 3 divisions amplitude.

(5) Adjust TI POSITIONING HORIZONTAL control to aline a marker with extreme left vertical division line. If TI crt does not display 1 marker every 2.5 divisions, and fifth marker is not within ± 0.5 division of extreme right vertical division line, perform b below.

(6) Disconnect equipment.

b. Adjustments

(1) Adjust C372 (fig. 2) for crt display of 1 marker every 2.5 divisions and fifth marker alined with extreme right vertical division line (R).

(2) Repeat performance check.

41. Variable Attenuator Balance

a. Performance Check

(1) Position TI controls as follows:

- (a) TRIGGER SELECTOR (black) switch to +INT.
- (b) TRIGGER SELECTOR (red) switch to AUTO.
- (c) HORIZONTAL DISPLAY switch to NORM.
- (d) TRIGGERING LEVEL control fully clockwise.
- (e) STABILITY control to PRESET.
- (f) TIME/DIV switch to .5 MILLISEC.
- (g) VARIABLE TIME/DIV control to CALIBRATED.
- (h) POSITIONING VERTICAL control to midrange.

- (i) POSITIONING HORIZONTAL control to midrange.
- (j) VOLTS/DIV switch to 1.
- (k) VARIABLE VOLTS/DIV control to CALIBRATED.
- (l) AC-DC switch to DC.

(2) Adjust TI VARIABLE VOLTS/DIV control fully counterclockwise. If TI crt display shifts vertically as VARIABLE VOLTS/DIV control is turned throughout its range, perform b below.

(3) Set TI VARIABLE VOLTS/DIV control to CALIBRATED.

b. Adjustments

(1) Adjust TI VARIABLE ATTEN BAL (front panel) adjustment for TI crt display of no vertical.

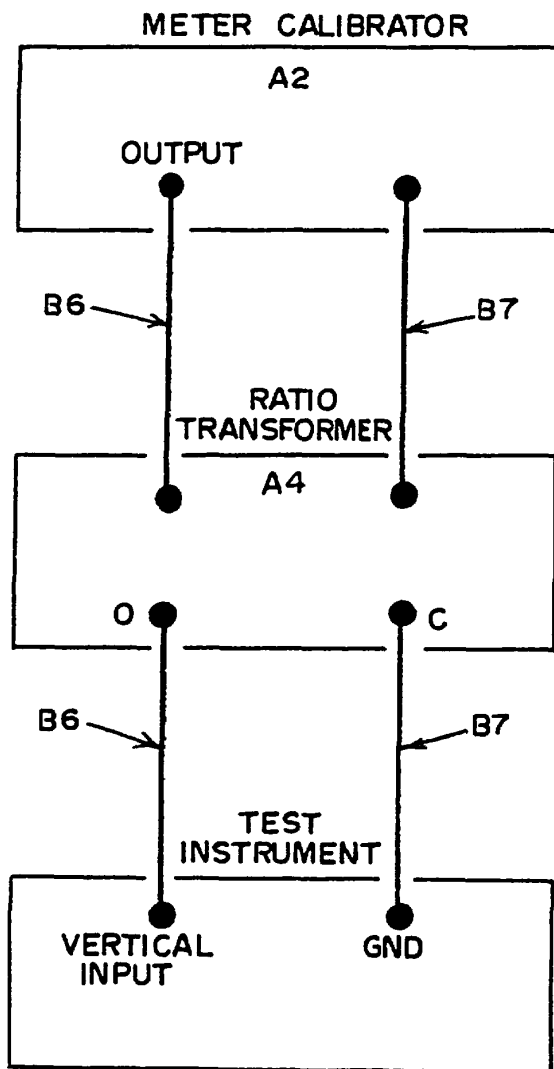

MSC00081

Figure 8. Amplifier gain and attenuation-equipment setup.

shift as VARIABLE VOLTS/DIV control is turned throughout its range.

(2) Set TI VARIABLE VOLTS/DIV control to CALIBRATED.

42. Amplifier Gain and Attenuation

a. Performance Check

- (1) Connect equipment as shown in figure 8.
- (2) Set TI AC-DC switch to DC.

(3) Set TI VOLTS/DIV switch to settings listed in table 12 and perform the following:

(a) Set meter calibrator (A2) decade dials to settings listed.

(b) Adjust meter calibrator output controls for 400 Hz and null indication on output meter.

(c) Adjust ratio transformer (A4) decade dials for TI crt display of 4 divisions peak-to-peak. If ratio transformer does not indicate within limits specified, perform b below.

Table 12. Amplifier Gain and Input Attenuator

Test Instrument VOLTS/DIV Switch Settings.	Meter Calibrator Decade Dials Settings.	Ratio Transformer Decade Dials Indications.	
		Min	Max
.05	000.3535	19400	20600
.1	000.3535	38800	41200
.2	000.3535	77600	82400
.5	003.5350	19400	20600
1	003.5350	38800	41200
2	003.5350	77600	82400
10	035.3500	19400	20600
20	035.3500	38800	41200
		77600	82400

(4) Adjust meter calibrator output controls for zero indication.

(5) Disconnect equipment.

b. Adjustments

(1) Set TI VOLTS/DIV switch to .1.

(2) Adjust ratio transformer decade dials for .40000.

(3) Adjust meter calibrator output controls for 000.3535 volt ac at 400 Hz.

(4) Adjust TI GAIN ADJ R244 (fig. 5) for crt display of 4.0 vertical divisions (R).

(5) Adjust ratio transformer decade dials for .20000.

(6) Set TI VOLTS/DIV switch to .05.

(7) Adjust II PREAMP GAIN ADJ R154 (fig. 5) for TI crt display of 4.0 vertical divisions (R).

(8) Repeat performance check.

43. Attenuator High-Frequency Compensation

a. Performance Check

(1) Connect square-wave generator (A6) OUTPUT to TI VERTICAL INPUT, using cable (B4).

(2) Adjust square-wave generator for 1 kHz output.

(3) Set TI VOLTS/DIV switch to .2, .5, 1, and 10. At each setting, adjust square-wave generator for crt display of 4 vertical divisions. If crt does not display an optimum square wave as shown in figure 9C, perform b below.

b. Adjustments. Set TI VOLTS/DIV switch to settings listed in table 13. Adjust TI adjustments listed for crt display of optimum square wave as shown in figure 9C.

Table 13. Attenuator High-Frequency Compensation Adjustments.

VOLTS/DIV Switch Settings.	Adjustments (fig. 5).
.2	C132 (R)
.5	C126 (R)
1	C118 (R)
10	C112 (R)

44. Attenuator Input Capacitance

a. Performance Check

(1) Connect 10X probe (provided with TI) to TI VERTICAL INPUT connector. Connect probe

tip and ground clip to square-wave generator (A6) output, using adapter (B3).

(2) Set square-wave generator SOURCE IMPEDANCE switch to INTERNAL 50Ω TERMINATION and TI VOLTS/DIV switch to .1.

(3) Adjust TI 10X probe variable capacitor (in

probe body) for crt display of square wave with optimum flat top as shown in figure 10C.

(4) Set TI VOLTS/DIV switch and squarewave generator SOURCE IMPEDANCE switch to positions listed in table 14. Adjust TI adjustments listed for crt display of square wave with optimum flat top as shown in figure 10C.

Table 14. Attenuator Input Capacitance

Test Instrument		Square-Wave Generator SOURCE IMPEDANCE Switch Settings.	Adjustments (fig. 5)
VOLTS/DIV Switch Settings.	Crt Display Amplitude (Divisions).		
.2	4	NORM	C130 (R)
.5	4	NORM	C124 (R)
1	4	NORM	C116 (R)
10	Approx 0.5	NORM	C110 (R)
.01	4	INTERNAL 50Ω TERMINATION	C141 (R) (fig. 6)

b. Adjustments. No further adjustments can be made.

45. Preamplifier Low-Frequency Compensation

a. Performance Check

(1) Set TI TIME/DIV switch to 10 MILLISEC and TI VOLTS/DIV switch to .01 AC ONLY.

(2) Adjust square-wave generator controls for crt display of 5 square waves of 4 vertical divisions. If TI crt does not display a square wave with optimum flat top as shown in figure 11A, perform b below.

(3) Disconnect equipment.

b. Adjustments. Adjust LOW-FREQ COMP R175 (fig. 5) for crt display of square wave with optimum flat top as shown in figure 11A (R).

46. Delay Line High-Frequency Response

a. Performance Check

(1) Position TI controls as follows:

(a) TRIGGER SELECTOR (black) switch to -INT.

(b) TRIGGER SELECTOR (red) switch to AC.

(c) HORIZONTAL DISPLAY switch to NORM.

(d) TRIGGERING LEVEL control to 0 (zero).

(e) STABILITY control to PRESET.

(f) TIME/DIV switch to 1 MILLISEC.

(g) VARIABLE TIME/DIV control to CALIBRATED.

(h) POSITIONING VERTICAL control to midrange.

(i) POSITIONING HORIZONTAL control to midrange.

(j) VOLTS/DIV switch to 1.

(k) VARIABLE VOLTS/DIV control to CALIBRATED.

(l) AC-DC switch to DC.

(m) CALIBRATOR VOLTS PEAK-TO-PEAK switch to OFF.

(2) Connect square-wave generator (A6) OUTPUT to TI VERTICAL INPUT, using cable (B4).

(3) Set square-wave generator SOURCE IMPEDANCE switch to INTERNAL 50Ω TERMINATION.

(4) Adjust square-wave generator frequency for 1 square-wave display and adjust amplitude for 4 centimeters of vertical deflection on TI crt.

(5) Adjust TI TRIGGERING LEVEL control for stable crt display. If TI crt does not display square wave with flat top (does not slope), no bumps or dips, and optimum square corner, as illustrated in figure 12A, perform b below.

(6) Set TI HORIZONTAL DISPLAY switch to MAG and TRIGGER SELECTOR (black) switch to +INT.

(7) Adjust TI POSITIONING HORIZONTAL control for TI crt display of leading edge of square wave.

(8) Measure rise time, using standard risetime technique. Rise time will be less than 0.9 minor divisions between 10 and 90 percent points.

b. Adjustments

(1) Adjust TI L150, L177 (fig. 6), L213, L227 L244, and L254 (fig. 6 or 13) for crt display or minimum rise time and optimum square corner (fig. 12A) (R).

(2) Adjust TI delay line capacitors (22 in line) for TI crt display of optimum flat-top square wave with no bumps or dips.

(3) Adjust TI L293, L294 (fig. 13), and C295 for crt display of flat top square wave (R).

NOTE

C295 is located in same vicinity as L293 and L294.

(4) Repeat (1) through (3) above for optimum TI crt square-wave display.

(5) Repeat performance check.

47. Amplifier Bandwidth

a. Performance Check

(1) Position TI controls as follows:

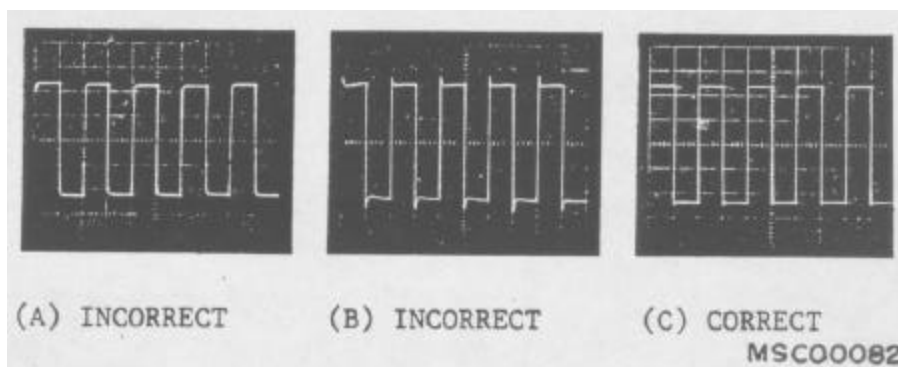

Figure 9. Attenuator high-frequency compensation waveforms.

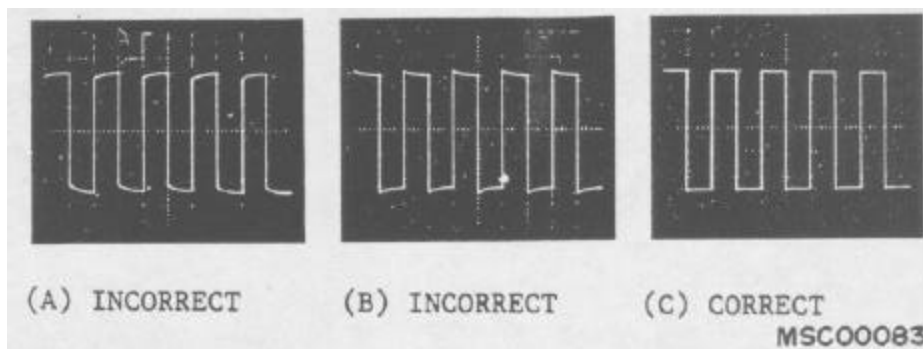

Figure 10. Attenuator input capacitance waveform.

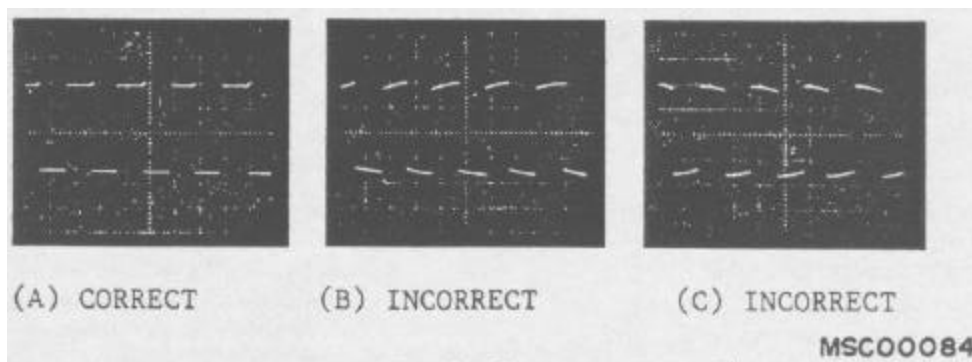

Figure 11. Preampifier low-frequency compensation waveforms.

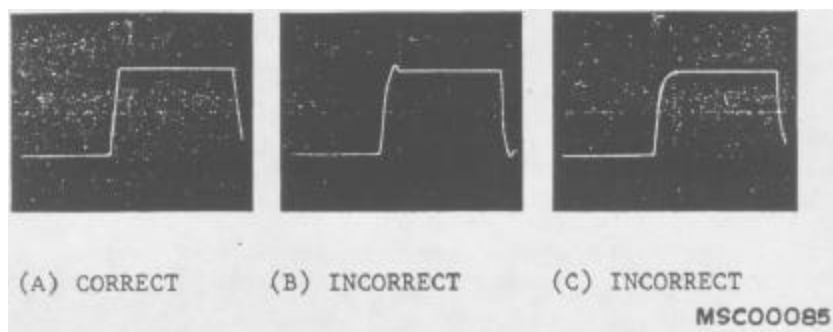

Figure 12. High-frequency response waveform.

- (a) TRIGGER SELECTOR (black) switch to +INT.
- (b) TRIGGER SELECTOR (red) switch to AUTO.
- (c) HORIZONTAL DISPLAY switch to NORM.
- (d) TRIGGERING LEVEL control fully clockwise.
- (e) STABILITY control to PRESET.
- (f) TIME/DIV switch to 1 MILLISEC.
- (g) VARIABLE TIME/DIV control to CALIBRATED.
- (h) POSITIONING VERTICAL control to midrange.
- (i) POSITIONING HORIZONTAL control to midrange.
- (j) VOLTS/DIV switch to .1.
- (k) VARIABLE VOLTS/DIV control to CALIBRATED.
- (l) AC-DC switch to AC.
- (m) CALIBRATOR VOLTS PEAK-TO-PEAK switch to OFF.

(2) Connect signal generator (A5) output to TI VERTICAL INPUT, using cable and adapter supplied with signal generator, and adapter (B3).

(3) Adjust signal generator for 50 kHz and amplitude for 6 vertical divisions on TI crt.

(4) Adjust signal generator to increase frequency for a 4.25-vertical division display on TI crt. Signal generator will indicate 10 MHz or greater.

b. Adjustments. No adjustments can be made.

48. Preamplifier bandwidth

a. Performance Check

(1) Set TI VOLTS/DIV switch to .01.

(2) Adjust signal generator (A5) for 50 kHz and amplitude for 6 vertical divisions of crt display.



Figure 13. High-frequency response--adjustment locations.

(3) Adjust signal generator for an increase in frequency for a 4.25-vertical division crt display. Signal generator will indicate 10 MHz or greater.

b. Adjustments. No adjustments can be made.

49. Power Supply

NOTE

Do not perform power supply check if all other parameters are within tolerance.

a. Performance Check

(1) Connect multimeter (A3) between -150V test point (fig. 6) and chassis ground, using leads (B6 and B7) and two adapters (B1). If multimeter does not indicate between 147 and 153 volts dc, perform *b(1)* below.

(2) Repeat technique of (1) above, using test points listed in table 15. Multimeter will indicate within limits specified.

(3) Connect multimeter between HV test point (fig. 5) and chassis ground, using leads (B6 and B7) and two adapters (B1). If multimeter does not indicate between -1261 and -1339 volts dc, perform *b*(2) below.

b. Adjustments

(1) Adjust -150 ADJ R617 (fig. 4) for a -150-volt indication on multimeter (R).

(2) Adjust H.V. ADJ R811 (fig. 2) for a -1300-volt dc indication on multimeter (R).

Table 15. Low-Voltage Power Supply

Test Instrument Test Points (fig. 6).	Multimeter Indications (v)	
	Min	Max
+100 V	+97	+103
+300 V	+291	+309

50. Final Procedure

- a. Deenergize and disconnect all equipment.
- b. In accordance with TM 38-750, annotate and

affix DA Label 80 (U.S. Army Calibration System). When the TI cannot be adjusted within tolerance, annotate and affix DA Form 2417 (Unserviceable or Limited Use tag).

By Order of the Secretary of the Army:

Official:

VERNE L. BOWERS

Major General, United States Army

The Adjutant General

CREIGHTON W. ABRAMS
General, United States Army
Chief of Staff

Distribution:

To be distributed in accordance with DA Form 12-34, Section II, (qty rqr block No. 75) requirements for Calibration Procedures Publications.

